

DESIGN NOTES

Unique High Efficiency 12V Converter Operates with Inputs from 6V to 28V – Design Note 233

Christopher B. Umminger

Generating an output DC voltage from an input voltage that can vary both above and below the regulation point is a challenging power supply problem with a variety of solutions. Flyback or forward converters work well, but are difficult to use if a small and efficient solution is desired at high output currents. A cascade of two converters, such as a boost followed by a buck or linear regulator, is another possibility. Alternately, one can use a switching regulator in a SEPIC configuration that requires two inductors and an intermediate capacitor. These solutions are complex and have a high cost in components, board area and efficiency. However, one can also use the LTC[®]1625 No R_{SENSE}[™] controller in a circuit that is capable of both up and down conversion and requires only a single inductor and no sense resistor.

12V Output, Single Inductor, Buck/Boost Converter

An example of such a circuit is shown in Figure 1 to provide a 12V output with inputs that can range from 6V to 18V. All of the circuitry to the left of the inductor is identical to a typical buck converter implemented with the LTC1625. However, now the output (right) side of the inductor is also switched using an additional MOSFET M3 and a diode D2. These two devices act like a boost

converter stage. During the first portion of each cycle, switches M1 and M3 are on while M2 is off. The input voltage is applied across the inductor and its current increases. After the LTC1625 current comparator trips, M1 and M3 are turned off and M2 and D2 conduct for the remainder of the cycle. During this time, current is delivered to the output while $-V_{OUT}$ is applied across the inductor and its current decreases.

LTC, LTC and LT are registered trademarks of Linear Technology Corporation. No R_{SENSE} is a trademark of Linear Technology Corporation.

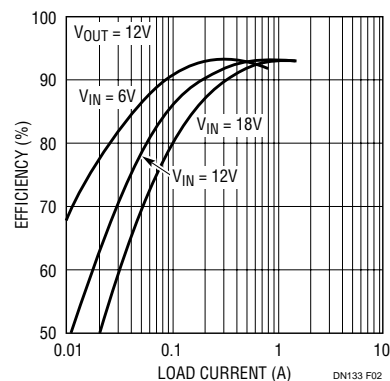

Figure 2. Efficiency of the 12V Output Single Inductor Buck/Boost Converter

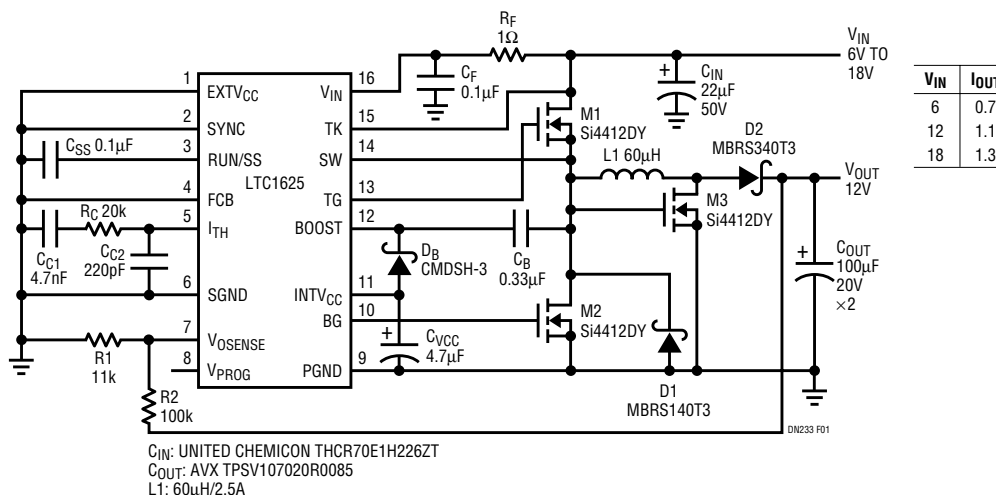

Figure 1. 12V Output Single Inductor Buck/Boost Converter

The duty cycle for the Figure 1 circuit is equal to $V_{OUT}/(V_{IN} + V_{OUT})$. When V_{IN} is equal to V_{OUT} , a fifty percent duty cycle is required to balance the volt-seconds across the inductor. Both the input and output capacitors must filter a square pulse current in this topology. The average value of the inductor current is equal to the sum of the input and output currents. Since the LTC1625 uses MOSFET V_{DS} sensing to control the inductor current peaks, the output current limit depends upon the duty cycle and will vary with the input voltage. At $V_{IN} = 12V$, the maximum output current is about 1.1A. Efficiency of the circuit is shown in Figure 2. Note that diode D2 prevents current reversal which causes cycle skipping at low load currents and improves the light load efficiency.

Synchronous Circuit for Higher Power, Higher V_{IN}

Several modifications can be made to the Figure 1 circuit to improve its operation as shown in Figure 3. In order to process more power, lower on-resistance MOSFET switches are used along with a higher current inductor. The number of input and output capacitors is also increased due to the higher RMS currents flowing through them.

At higher power levels, it is desirable to use a synchronous switch M4 across the output diode D2, allowing one to

reduce the current rating of D2 and improve the converter efficiency. Gate drive for this switch is derived from the LTC1625 BG pin, buffered by the LTC1693-2 and then level shifted to the output with the network formed by C4, R4 and D4. Another change increases the allowed input voltage, which is limited in the Figure 1 circuit by the breakdown voltage of the M3 gate. This impediment is overcome using a clamp network formed by R5, C3 and Z1 to derive the turn-on signal for switch M3. The signal is buffered by the other half of the LTC1693-2 to drive M3. The efficiency of this circuit is shown in Figure 4.

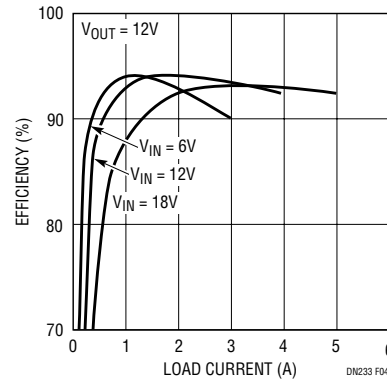

Figure 4. Efficiency of the Synchronous Buck/Boost Circuit

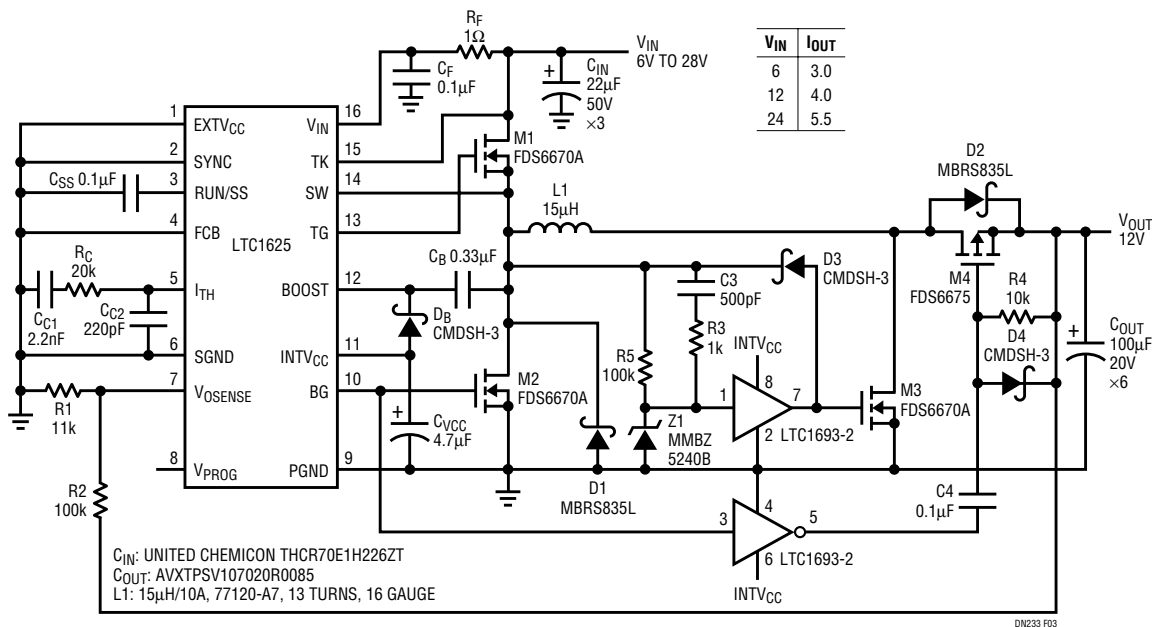

Figure 3. Synchronous 12V Output Buck/Boost Converter

Data Sheet Download

<http://www.linear-tech.com/go/dnLTC1625>

For literature on our Switching Regulators, call **1-800-4-LINEAR**. For applications help, call (408) 432-1900, Ext. 2593